

(IT) Attenzione: Istruzioni di montaggio per barre in alluminio.
(GB) Attention: Mounting instructions for aluminium bar carriers.
(E) Atención: Instrucciones de montaje para barras portatodo en aluminio.
(D) Achtung: Montageanweisungen für Aluminium-Lastenträger.
(F) Attention: Notices de montage pour barres de portage en aluminium.
(NL) Attentie: Handleiding voor dakdragers gemaakt van aluminium.
(P) Atenção: Instruções de montagem para barras de tejadilho em alumínio.
(H) Szerelési utasítás aluminium tartórudakhoz.
(PL) Uwaga: Instrukcja montażu bagażników wykonanych ze aluminium.
(SLO) Pozor: Navodila za montažo nosilcev prtljažnika - aluminijastih.
(HR) Uputstvo za montažu aluminijaskih nosača.

1

ZOOM

(IT) SVITARE
(GB) UNSCREW
(E) AFLOJAR
(D) ABSCHRAUBEN
(F) DEVISSER
(NL) OPENSCHROEVEN
(P) DESAPARAFUSAR
(H) KICSAVARNI
(PL) WYKRECIC
(SLO) ODVITI
(HR) ODVITI

A

B

(IT) INSERIRE
(GB) INSERT
(E) CUBRIR
(D) STOPFEN
(F) ENFILER
(NL) BEVESTIG

C

(IT) INSERIRE
(GB) INSERT
(E) CUBRIR
(D) STOPFEN
(F) ENFILER
(NL) BEVESTIG

D

(IT) AVVITARE
(GB) TO SCREW
(E) APRETAR
(D) FESTSCHRAUBEN
(F) VISSER
(NL) VASTSCHROEVEN

(P) APERTAR
(H) MEGHÚZNI
(PL) WKRECIC
(SLO) PRIVITI
(HR) PRIČVRSTITI

2

OK

ZOOM

(IT) INSERIRE
(GB) INSERT
(E) CUBRIR
(D) STOPFEN
(F) ENFILER
(NL) BEVESTIG

(P) INSERIR
(H) TOLJA FEL
(PL) NALOZIC
(SLO) VSTAVITI
(HR) PREKRITI

3

<p>(IT) MODELLI AUTO (GB) CARS (E) COCHES (D) WAGEN (F) VOITURES</p>	<p>(NL) AUTO (P) MODELO AUTO (H) AUTÓ TÍPUS (PL) MODELE SAMOCHODÓW (SLO) MODELI AVTOMOBILOV (HR) MODELI AUTA</p>	<p>(IT) ANTERIORE (GB) FRONT (E) DELANTERO (D) VORDERE (F) AVANT</p>	<p>(NL) VOORSTE G. (P) À FRENTE (H) ELSŐ RÚD (PL) PRZOD (SLO) SPREDAJ (HR) PREDNJI</p>	<p>(IT) POST. (GB) REAR (E) TRASERO (D) HINTERE (F) ARRIERE</p>	<p>(NL) ACHTERSTE G. (P) ATRÁS (H) HÁTSÓ RÚD (PL) TYŁ (SLO) ZADAJ (HR) STRAŽNJI</p>
<p>LANCIA DELTA (08->)</p>		<p>78 mm</p>		<p>110 mm</p>	

ZOOM

(IT) MISURE PRECISE
(GB) EXACT DIMENSIONS
(E) MEDIDAS CORRECTAS
(D) GENAUE MASSE
(F) MESURES EXACTES
(NL) EXACTE AFMETINGEN
(P) MEDIDAS PRECISAS
(H) PONTOS MÉRET
(PL) DOKŁADNE WYMIARY
(SLO) TOČNE MERE
(HR) PRECIZNE MJERE

ZOOM

4

(IT) AVVITARE (A FONDO)
(GB) TO SCREW (DOWN)
(E) APRETAR (A FONDO)
(D) FESTSCHRAUBEN
(F) VISSER (À FOND)
(NL) VASTSCHROEVEN
(P) APERTAR POR BAIXO
(H) MEGHÚZNI
(PL) WKRECIC DO KONCA
(SLO) PRIVITI (DO KONCA)
(HR) PRIČVRSTITI (DO KRAJA)

10 Nm

5

(IT) INSERIRE
(GB) INSERT
(E) CUBRIR
(D) STOPFEN
(F) ENFILER
(P) INSERIR
(NL) BEVESTIG
(H) TOLJA FEL
(PL) NALOZIC
(SLO) VSTAVITI
(HR) PREKRITI

6

(IT) TAGLIARE
(GB) TO CUT
(E) CORTAR
(D) SCHNEIDEN
(F) COUPER
(NL) SNIJDEN
(P) CORTAR
(H) ELVÁGNI
(PL) OBCIAC
(SLO) ODREZATI
(HR) ODREZATI

A

B

(IT) INSERIRE
(GB) INSERT
(E) CUBRIR
(D) STOPFEN
(F) ENFILER
(P) INSERIR
(NL) BEVESTIG
(H) TOLJA FEL
(PL) NALOZIC
(SLO) VSTAVITI
(HR) PREKRITI

7

(IT) INSERIRE
(GB) INSERT
(E) CUBRIR
(D) STOPFEN
(F) ENFILER
(NL) BEVESTIG

(P) INSERIR
(H) TOLJA FEL
(PL) NALOZIC
(SLO) VSTAVITI
(HR) PREKRITI

A

(IT) INSERIRE
(GB) INSERT
(E) CUBRIR
(D) STOPFEN
(F) ENFILER
(NL) BEVESTIG

B

(IT) TAGLIARE
(GB) TO CUT
(E) CORTAR
(D) SCHNEIDEN
(F) COUPER
(NL) SNIJDEN
(P) CORTAR
(H) ELVÁGNI
(PL) OBCIAC
(SLO) ODREZATI
(HR) ODREZATI

8

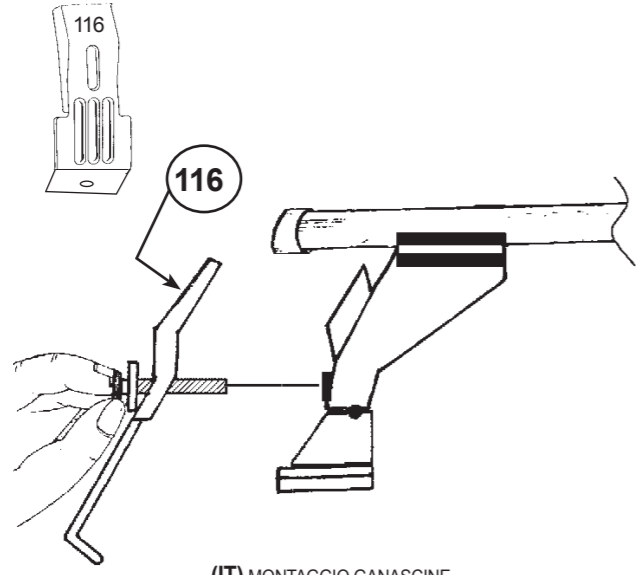

(IT) MONTAGGIO GANASCINE
 (GB) HOW TO ASSEMBLE THE CLAMPS
 (E) COMO MONTAR LAS FIJACIONES
 (D) ZUSAMMENBAU DER SPANNBACKEN
 (F) MONTAGE PATTE
 (NL) MONTAGE VAN DE KLEMMEN
 (P) COMO FIXAR OS SUPORTES
 (H) RÖGZÍTŐ FÜLEK
 (PL) MONTAZ SZCZEK MOCUJACYCH
 (SLO) MONTAŽA NAPENJALNIKA
 (HR) MONTAŽA ČELJUSTI

9

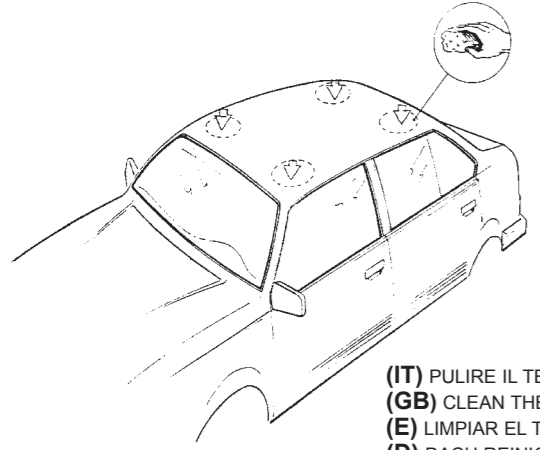

(IT) PULIRE IL TETTO
 (GB) CLEAN THE ROOF
 (E) LIMPIAR EL TECHO
 (D) DACH REINIGEN
 (F) NETTOYER LE TOIT
 (NL) DAK SCHOONMAKEN
 (P) LIMPAR O TEJADILHO
 (H) TISZTÍTSÁ MEG A TETŐT
 (PL) WYCZYŚCIC DACH
 (SLO) OČISTITI STREHO
 (HR) ČIŠĆENJE KROVA

10

(IT) CENTRARE IL P. TUTTO SUL TETTO
 (GB) CENTRE THE UNIVERSAL BAR CARRIER ON THE ROOF
 (E) CENTRAR EL PORTAEQUIPAJES SOBRE EL TECHO
 (D) LASTENTRÄGER AUF DEM DACH ZENTRIEREN
 (F) CENTRER LE PORTE-TOUT SUR LE TOIT
 (NL) PLAATS DE UNIVERSELE DRAGER IN HET MIDDEN VAN HET DAK
 (P) CENTRAR AS BARRAS PORTA BAGAGENS NO TEJADILHO
 (H) HELYEZZE KÖZÉPRE A RUDAKAT
 (PL) WYSRODKOWAC BAGAŻNIK NA DACHU
 (SLO) CENTRIRATI PRTLJAŽNIK NA STREHO
 (HR) CENTRIRATI NOSAČE NA KROV

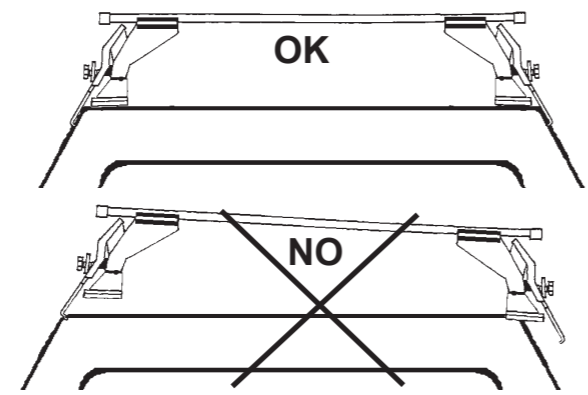

(IT) MODELLI CON PREDISPOSIZIONE DELLA CASA AUTO
 (GB) CARS WITH PRE-EXISTING FIXING POINT FROM MANUFACTURER
 (E) MODELOS CON PREDISPOSICION DEL FABRICANTE
 (D) AUTOS MIT VOM HERSTELLER VORGESEHENE BEFESTIGUNGSPUNKTE
 (F) VOITURES AVEC POINTS DE RÉPÈRE PREVUS PAR LE CONSTRUCTEUR
 (NL) AUTO'S MET DOOR DE FABRIKANT VOORZIENE MONTAGEPUNTEN
 (P) VIATURAS COM PONTOS DE FIXAÇÃO DO CONSTRUTOR PRÉ-EXISTENTES
 (H) FELHÉLYEZÉS GYÁRTÓ ÁLTAL KIJELÖLT PONTRA
 (PL) SAMOCHODY Z PRZEWIDZIANYMI PUNKTAMI UMOCOWANIA
 (SLO) MODELI Z PREDVIDENIM LEŽIŠČEM S STRANI PROIZVAJALCA
 (HR) TVORNIČKI PRIPREMLJENI MODELI

“À TROUVER SUR LE BATTANT DE LA PORTE OU DANS LE MANUAL TECHNIQUE DE LA VOITURE “

11

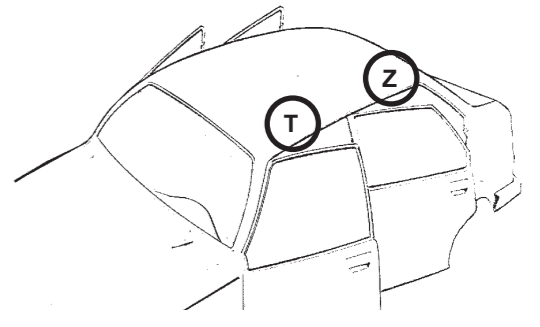

(IT) MODELLI AUTO (GB) CARS (E) COCHES (D) WAGEN (F) VOITURES (NL) AUTO (P) MODELO AUTO (H) AUTÓ TIPUS (PL) MODELE SAMOCHODÓW (SLO) MODELI AVTOMOBILOV (HR) MODELI AUTA	(IT) ANTERIORE (GB) FRONT (E) DELANTERO (D) VORDERE (F) AVANT (NL) VOORSTE G. (P) À FRENTE (H) ELSŐ RÚD (PL) PRZOD (SLO) SPREDAJ (HR) PREDNJI	(IT) POSTERIORE (GB) REAR (E) TRASERO (D) HINTERE (F) ARRIERE (NL) ACHTERSTE G. (P) ATRÁS (H) HÁTSÓ RÚD (PL) TYŁ (SLO) ZADAJ (HR) STRAŽNJI
LANCIA DELTA (08->)	T	Z

(IT) ANTERIORE
 (GB) FRONT
 (E) DELANTERO
 (D) VORDERE
 (F) AVANT
 (NL) VOORSTE G.
 (P) À FRENTE
 (H) ELSŐ RÚD
 (PL) PRZOD
 (SLO) SPREDAJ
 (HR) PREDNJI

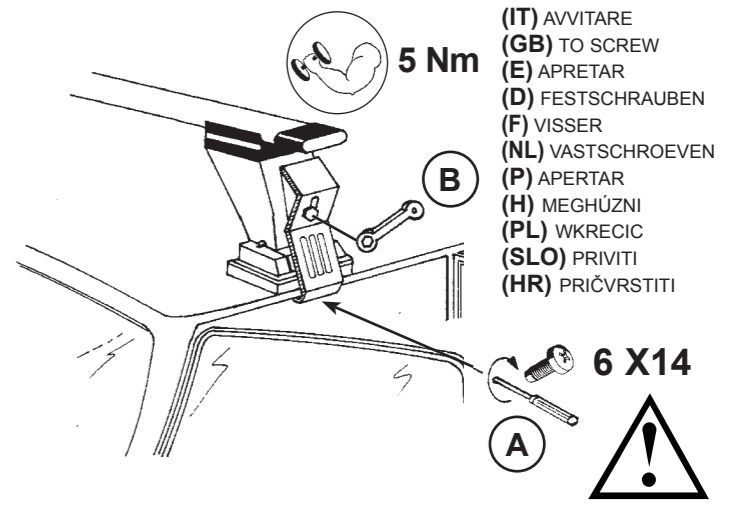
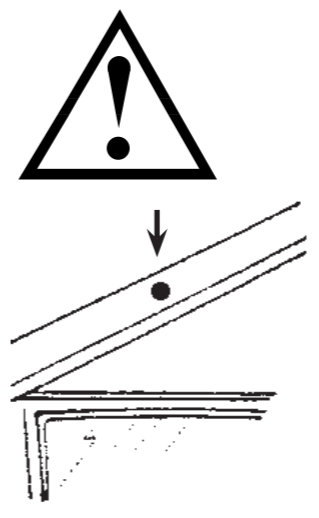

(IT) POSTERIORE
 (GB) REAR
 (E) TRASERO
 (D) HINTERE
 (F) ARRIERE
 (NL) ACHTERSTE G.
 (P) ATRÁS
 (H) HÁTSÓ RÚD
 (PL) TYŁ
 (SLO) ZADAJ
 (HR) STRAŽNJI

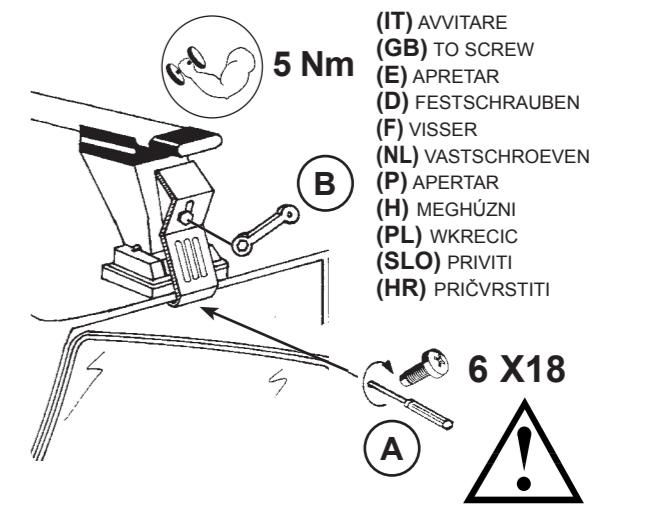
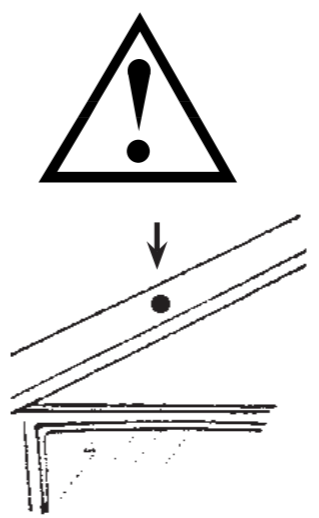



(IT) **Attenzione:** Istruzioni di montaggio per barre in ferro.
 (GB) **Attention:** Mounting instructions for steel bar carriers.
 (E) **Atencion:** Instrucciones de montaje para barras portatodo en hierro.
 (D) **Achtung:** Montageanweisungen für Stahl-Lastenträger.
 (F) **Attention:** Notices de montage pour barres de portage en métal.
 (NL) **Attentie:** Handleiding voor dakdragers gemaakt van ijzer.
 (P) **Atenção:** Intruções de montagem para barras de tejadilho em ferro.
 (H) **Szerelési utasítás** acél tartórudakhoz.
 (PL) **Uwaga:** Instrukcja montażu bagażników wykonanych ze stali.
 (SLO) **Pozor:** Navodila za montažo nosilcev prtljažnika-železnih.
 (HR) **Uputstvo za** montažu željeznih krovnih nosača.

1

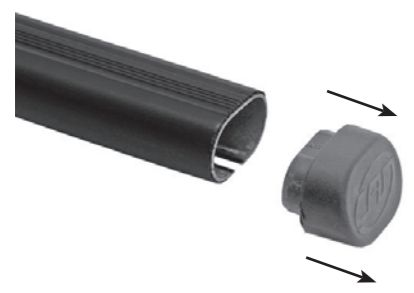

2

(IT) INSERIRE
 (GB) INSERT
 (E) CUBRIR
 (D) STOPFEN
 (F) ENFILER
 (NL) BEVESTIG
 (P) INSERIR
 (H) TOLJA FEL
 (PL) NALOZIC
 (SLO) VSTAVITI
 (HR) PREKRITI

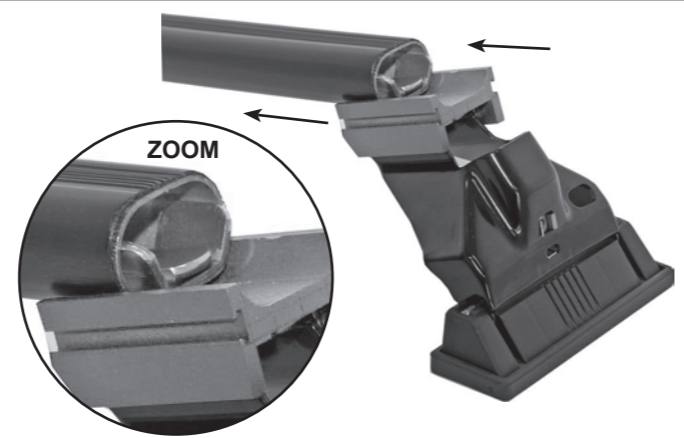

3

(IT) MODELLI AUTO (GB) CARS (E) COCHES (D) WAGEN (F) VOITURES	(IT) ANTERIORE (GB) FRONT (E) DELANTERO (D) VORDERE (F) AVANT	(IT) POST. (GB) REAR (E) TRASERO (D) HINTERE (F) ARRIERE
(NL) AUTO (P) MODELO AUTO (H) AUTÓ TIPUS (PL) MODELE SAMOCHODÓW (SLO) MODELI AVTOMOBILÓV (HR) MODELI AUTA	(NL) VOORSTE G. (P) Á FRENTE (H) ELSŐ RÚD (PL) PRZOD (SLO) SPREDAJ (HR) PREDNJI	(NL) ACHTERSTE G. (P) ATRÁS (H) HÁTSÓ RÚD (PL) TYŁ (SLO) ZADAJ (HR) STRAŽNJI
LANCIA DELTA (08->)	78 mm	110 mm

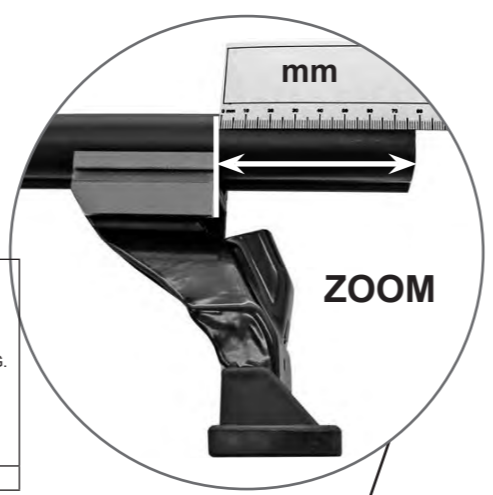

(IT) MISURE PRECISE
 (GB) EXACT DIMENSIONS
 (E) MEDIDAS CORRECTAS
 (D) GENAU MASSE
 (F) MESURES EXACTES
 (NL) EXACTE AFMETINGEN
 (P) MEDIDAS PRECISAS
 (H) PONTOS MÉRET
 (PL) DOKŁADNE WYMIARY
 (SLO) TOČNE MERE
 (HR) PRECIZNE MJERE

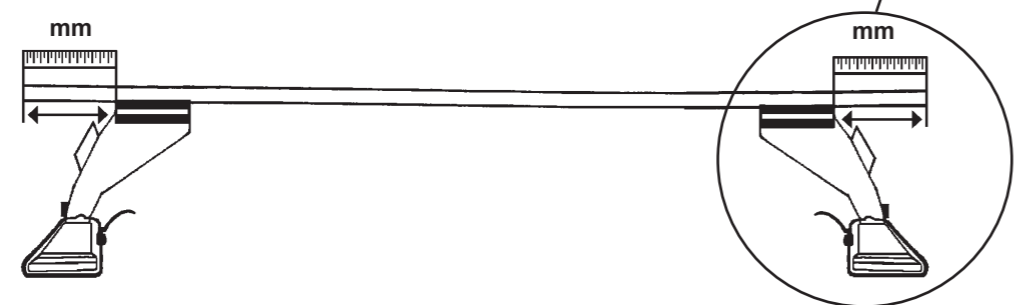

4

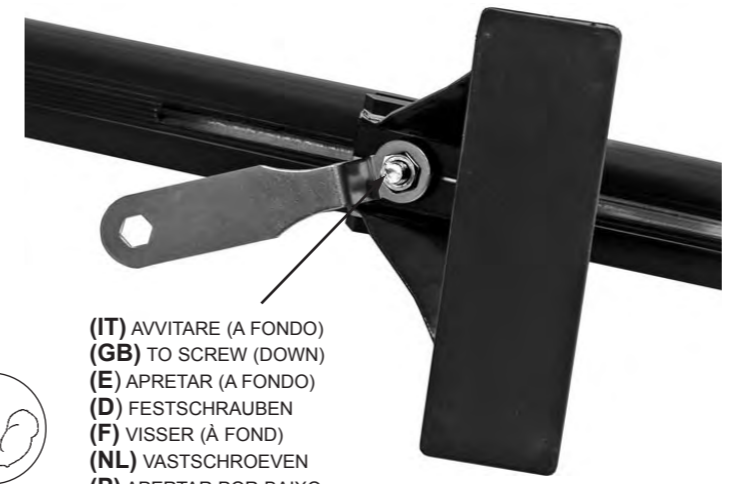

10 Nm

(IT) AVVITARE (A FONDO)
 (GB) TO SCREW (DOWN)
 (E) APRETAR (A FONDO)
 (D) FESTSCHRAUBEN
 (F) VISSER (À FOND)
 (NL) VASTSCHROEVEN
 (P) APERTAR POR BAIXO
 (H) MEGHÚZNI
 (PL) WKRECIC DO KONCA
 (SLO) PRIVITI (DO KONCA)
 (HR) PRIČVRSTITI (DO KRAJA)

5



(IT) INSERIRE
 (GB) INSERT
 (E) CUBRIR
 (D) STOPFEN
 (F) ENFILER
 (NL) BEVESTIG
 (P) INSERIR
 (H) TOLJA FEL
 (PL) NALOZIC
 (SLO) VSTAVITI
 (HR) PREKRITI

6

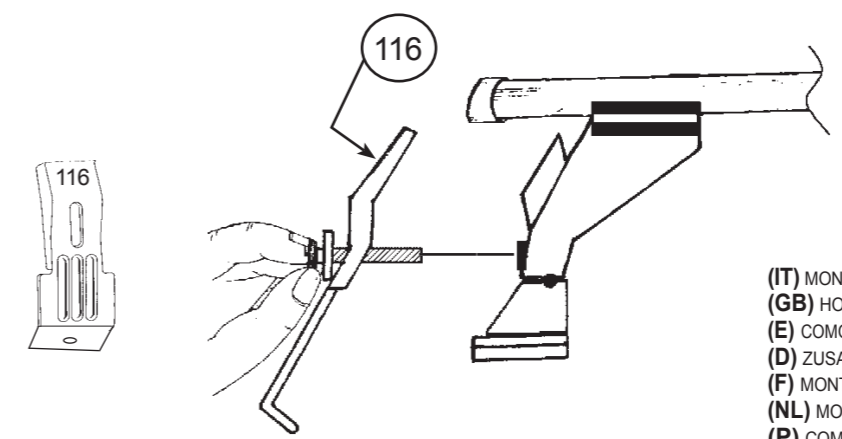

(IT) MONTAGGIO GANASCINE
 (GB) HOW TO ASSEMBLE THE CLAMPS
 (E) COMO MONTAR LAS FIJACIONES
 (D) ZUSAMMENBAU DER SPANNBACKEN
 (F) MONTAGE PATTE
 (NL) MONTAGE VAN DE KLEMMEN
 (P) COMO FIXAR OS SUPORTES
 (H) RÖGZÍTŐ FÜLEK
 (PL) MONTAZ SZCZEK MOCUJACYCH
 (SLO) MONTAŽA NAPENJALNIKA
 (HR) MONTAŽA ČELJUSTI

7

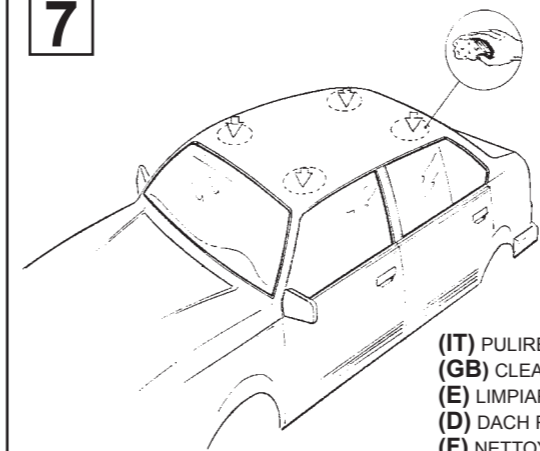

(IT) PULIRE IL TETTO
 (GB) CLEAN THE ROOF
 (E) LIMPIAR EL TECHO
 (D) DACH REINIGEN
 (F) NETTOYER LE TOIT
 (NL) DAK SCHOONMAKEN
 (P) LIMPAR O TEJADILHO
 (H) TISZTÍTSA MEG A TETŐT
 (PL) WYCZYSCIC DACH
 (SLO) OČISTITI STREHO
 (HR) ČIŠĆENJE KROVA

8

(IT) CENTRARE IL P. TUTTO SUL TETTO
 (GB) CENTRE THE UNIVERSAL BAR CARRIER ON THE ROOF
 (E) CENTRAR EL PORTAEQUIPAJES SOBRE EL TECHO
 (D) LASTENTRÄGER AUF DEM DACH ZENTRIEREN
 (F) CENTRER LE PORTE-TOUT SUR LE TOIT
 (NL) PLAATS DE UNIVERSELE DRAGER IN HET MIDDEN VAN HET DAK
 (P) CENTRAR AS BARRAS PORTA BAGAGENS NO TEJADILHO
 (H) HELYEZZE KÖZÉPRE A RUDAKAT
 (PL) WYSRODKOWAC BAGAZNIK NA DACHU
 (SLO) CENTRIRATI PRTLJAŽNIK NA STREHO
 (HR) CENTRIRATI NOSAČE NA KROV

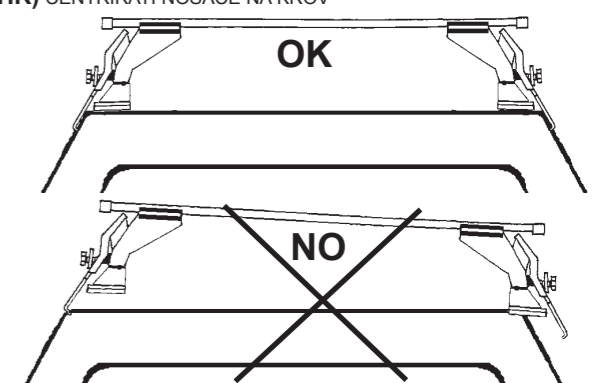

- (IT) MODELLI CON PREDISPOSIZIONE DELLA CASA AUTO
 (GB) CARS WITH PRE-EXISTING FIXING POINT FROM MANUFACTURER
 (E) MODELOS CON PREDISPOSICION DEL FABRICANTE
 (D) AUTOS MIT VOM HERSTELLER VORGESEHENE BEFESTIGUNGSPUNKTE
 (F) VOITURES AVEC POINTS DE RÉPÈRE PREVUS PAR LE CONSTRUCTEUR
 (NL) AUTO'S MET DOOR DE FABRIKANT VOORZIENE MONTAGEPUNTEN
 (P) VIATURAS COM PONTOS DE FIXAÇÃO DO CONSTRUTOR PRÉ-EXISTENTES
 (H) FELHÉLYEZÉS GYÁRTÓ ÁLTAL KIJELÖLT PONTRA
 (PL) SAMOCHODY Z PRZEWIDZIANYMI PUNKTAMI UMOCOWANIA
 (SLO) MODELI Z PREDVIDENIM LEŽIŠČEM S STRANI PROIZVAJALCA
 (HR) TVORNIČKI PRIPREMLJENI MODELI

“À TROUVER SUR LE BATTANT DE LA PORTE OU
 DANS LE MANUAL TECHNIQUE DE LA VOITURE “

9

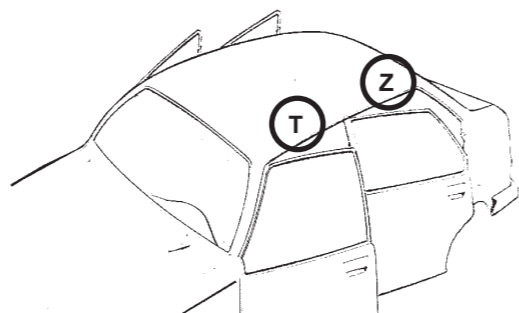

(IT) MODELLI AUTO (GB) CARS (E) COCHES (D) WAGEN (F) VOITURES (NL) AUTO (P) MODELO AUTO (H) AUTÓ TIPUS (PL) MODELE SAMOCHODÓW (SLO) MODELI AVTOMOBILOV (HR) MODELI AUTA	(IT) ANTERIORE (GB) FRONT (E) DELANTERO (D) VORDERE (F) AVANT (NL) VOORSTE G. (P) À FRENTE (H) ELSÓ RÚD (PL) PRZOD (SLO) SPREDAJ (HR) PREDNJI	(IT) POSTERIORE (GB) REAR (E) TRASERO (D) HINTERE (F) ARRIERE (NL) ACHTERSTE G. (P) ATRÁS (H) HÁTSÓ RÚD (PL) TYL (SLO) ZADAJ (HR) STRAŽNJI
LANCIA DELTA (08->)	T	Z

- (IT) ANTERIORE
(GB) FRONT
(E) DELANTERO
(D) VORDERE
(F) AVANT
(NL) VOORSTE G.
(P) À FRENTE
(H) ELSÓ RÚD
(PL) PRZOD
(SLO) SPREDAJ
(HR) PREDNJI

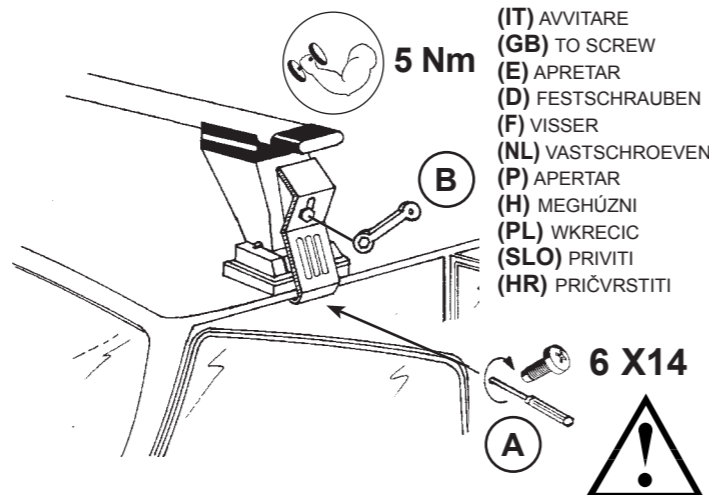
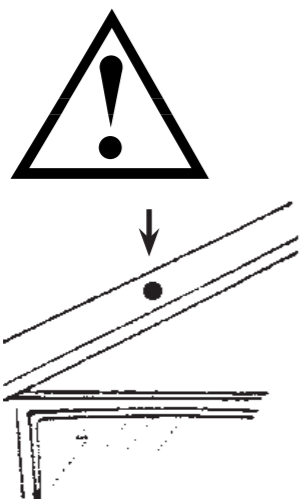

- (IT) AVVITARE
(GB) TO SCREW
(E) APRETAR
(D) FESTSCHRAUBEN
(F) VISSER
(NL) VASTSCHROEVEN
(P) APERTAR
(H) MEGHÚZNI
(PL) WKRECIC
(SLO) PRIVITI
(HR) PRIČVRSTITI

- (IT) POSTERIORE
(GB) REAR
(E) TRASERO
(D) HINTERE
(F) ARRIERE
(NL) ACHTERSTE G.
(P) ATRÁS
(H) HÁTSÓ RÚD
(PL) TYL
(SLO) ZADAJ
(HR) STRAŽNJI

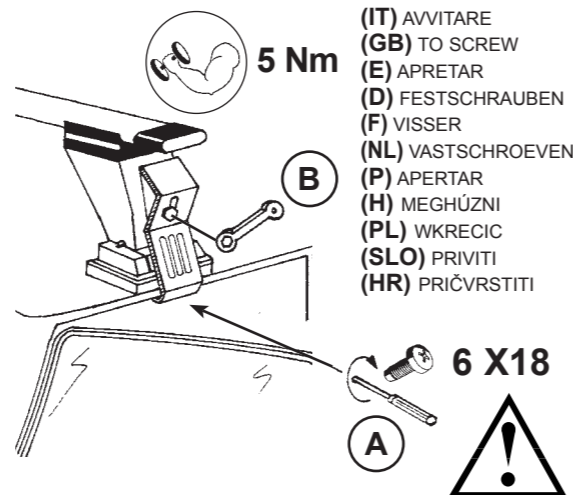
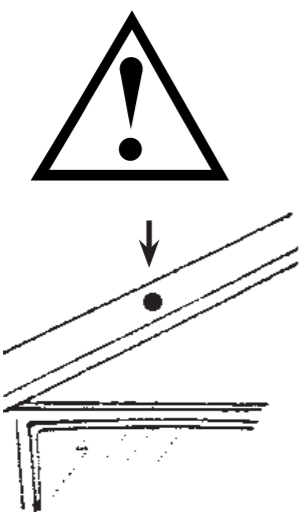

- (IT) AVVITARE
(GB) TO SCREW
(E) APRETAR
(D) FESTSCHRAUBEN
(F) VISSER
(NL) VASTSCHROEVEN
(P) APERTAR
(H) MEGHÚZNI
(PL) WKRECIC
(SLO) PRIVITI
(HR) PRIČVRSTITI

40116 PARTS LIST

x4 Cod. VTBS08P30



x4 Cod. 32052/Z



x4 Cod. ROZB08016



x4 Cod. DDFZ08001



x4 Cod. 60328

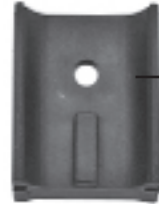

x4 Cod. 32053/Z

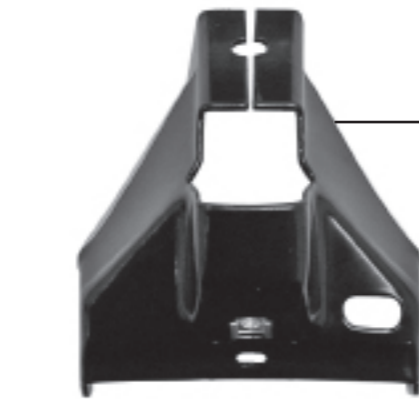
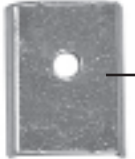

x4 Cod. 31051/V



x4 Cod. 57619



x4 Cod. DDFZ06006



x4 Cod. 60243

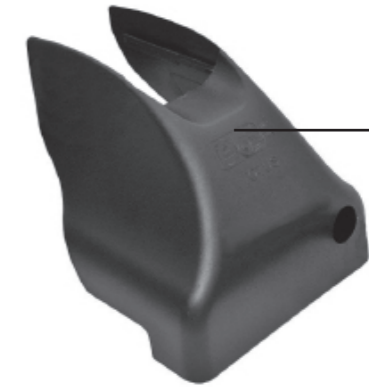

x4 Cod. 60239



x4 Cod. 60263



x1 Cod. 60273

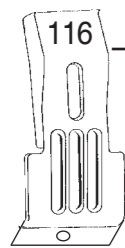

x4 Cod. 31158/V

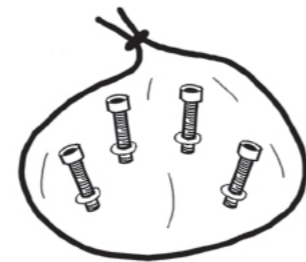

x1 Cod. 37930/M

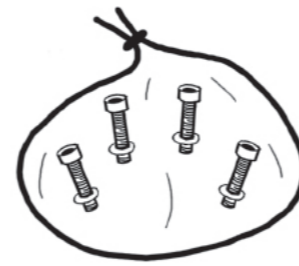

x1 Cod. 37976/M



mm

x1 Cod. 55099



x1 Cod. 32032/Z

COVER TOTUS

(IT) ISTRUZIONI DI MONTAGGIO (GB) FITTING INSTRUCTIONS (E) INSTRUCCIONES PARA SU MONTAJE
(D) MONTAGEANWEISUNGEN (F) INSTRUCTIONS DE MONTAGE (NL) MONTAGE INSTRUCTIES (P) INSTRUÇÕES DE MONTAGEM
(H) SZERELÉSI UTASÍTÁS (PL) INSTRUKCJA MONTAŻU (SLO) NAVODILA O MONTAŽI (HR) UPUTE ZA MONTAŽU.

1



(IT) INSERIRE
(GB) INSERT
(E) CUBRIR
(D) STOPFEN
(F) ENFILER
(P) INSERIR
(NL) BEVESTIG
(H) TOLJA FEL
(PL) NALOZIC
(SLO) VSTAVITI
(HR) PREKRITI



2

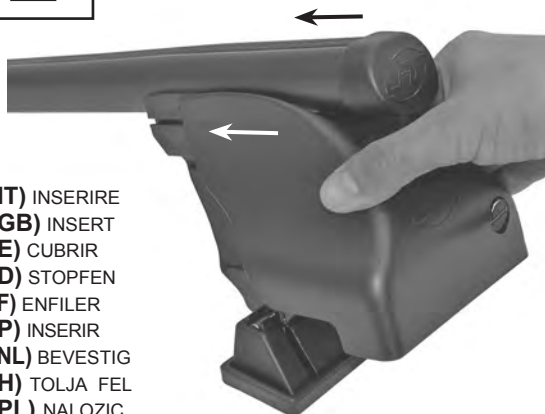

(IT) INSERIRE
(GB) INSERT
(E) CUBRIR
(D) STOPFEN
(F) ENFILER
(P) INSERIR
(NL) BEVESTIG
(H) TOLJA FEL
(PL) NALOZIC
(SLO) VSTAVITI
(HR) PREKRITI

3



4



(IT) INSERIRE
(GB) INSERT
(E) CUBRIR
(D) STOPFEN
(F) ENFILER
(P) INSERIR
(NL) BEVESTIG
(H) TOLJA FEL
(PL) NALOZIC
(SLO) VSTAVITI
(HR) PREKRITI



NO PER ART. 40102 - 40115 - 40119